



Doosan Machine Tools

COVER ALL ANGLES™

FULL 5-AXIS MACHINING BROCHURE

**MACHINE
GREATNESS™**

Why 5-Axis Machining?



Single Setup **Efficiency**

In both 5-sided machining (also known as 3+2 machining) and full 5-axis simultaneous machining, you're able to approach the workpiece from all angles, with complete access to five sides of the part in a single setup. This reduces the overall number of part setups compared to traditional machining, minimizing machine downtime and maximizing chip making time.



Improved Part **Accuracy**

When making parts with multi-sided features using traditional 3-axis machining, multiple part setups are required, enabling new inaccuracies to be created each time the workpiece is repositioned. 5-axis machining allows the part to be machined in a single setup, eliminating stacked tolerances and improving overall part dimensional accuracy.

Extended Machine Shop **Capability**

Doosan 5-axis machines open up new doors for your machine shop. The increased efficiency will make you instantly more competitive, and full 5-axis machining capabilities give you the opportunity to quote on jobs that previously weren't possible. What are you going to make today?

"We have really diversified manufacturing needs, and the DVF 5000 lets us perform a variety of processes quickly with outstanding results."

—OMGM Group, Italy



"Our Doosan 5-axis is making complex, high precision parts for aerospace and defense. Cycle times have been reduced dramatically."

—Aerotech Precision Manufacturing, Great Britain

Cover All Possibilities

The powerful and versatile 5-axis machine lineup at Doosan is an unbeatable option for machine shops that want to enjoy limitless part-making possibilities.

DNM / 5AX series

The perfect entry into 5-axis machining. Compact, productive and built off the classic DNM architecture.

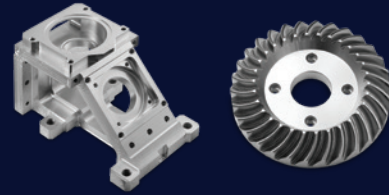

DVF series

With cutting-edge technology and an automation-ready framework, this machine elevates your 5-axis capability.



FM / 5AX series

Our ultra high speed and ultra precise linear motor series. 42000 r/min spindle speed with outstanding accuracy.



VCF 850SR/LSR

Our traveling column vertical machining center with a rotating B-axis spindle head and C-axis table is a fantastically flexible way to get more 5-axis production out of a single machine.

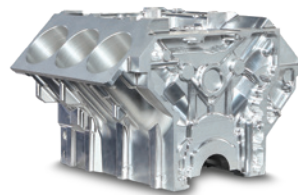

DHF series

A powerful twin-pallet machine for larger, complex parts. Handle those big parts with maximum efficiency.



BM U series

An accurate and rigid bridge mill VMC. Capably handles the biggest parts for the biggest industries—aerospace, construction, oil/gas and more.

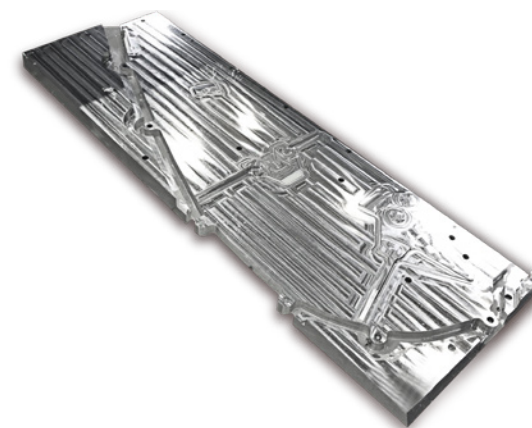

HFP series

A 5-axis super high performance machine for our larger aluminum structural components with 5 kW, 30000 r/min spindle.



Cover All Configurations

From research to engineering to installation to support, no one builds 5-axis machines like Doosan. We have all angles covered so our customers can enjoy complete machining freedom.

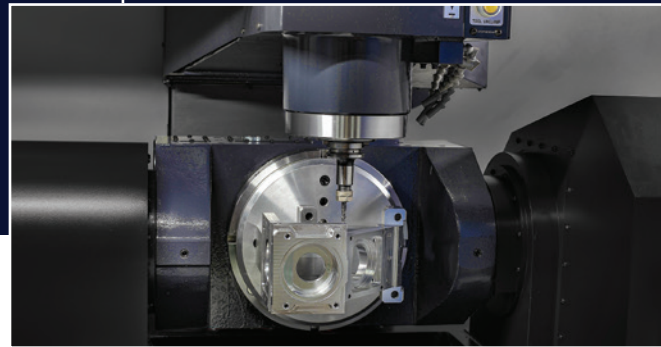
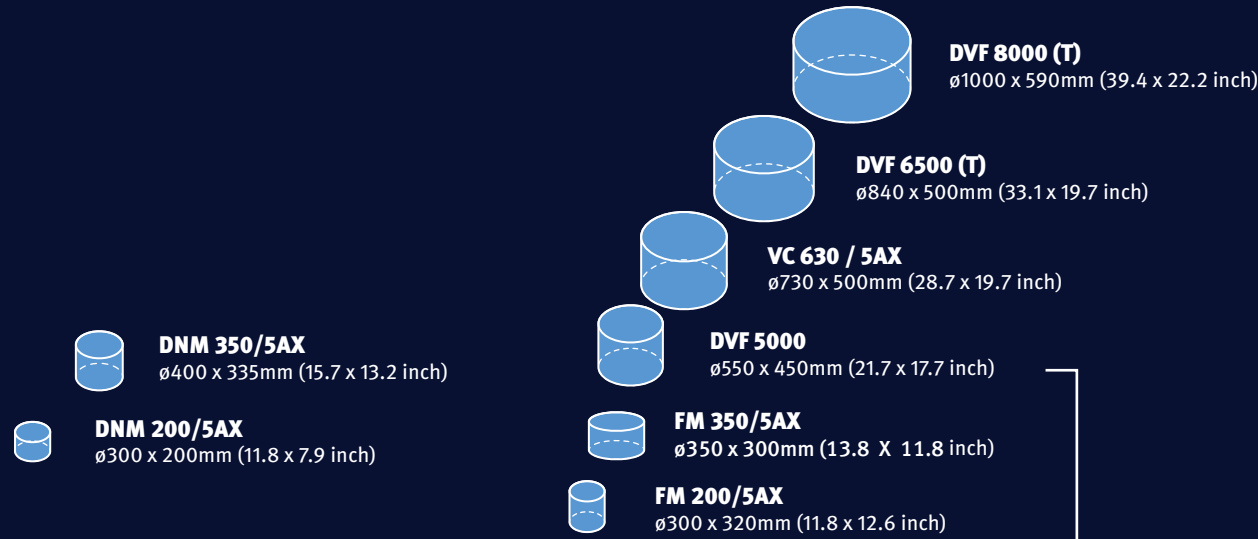
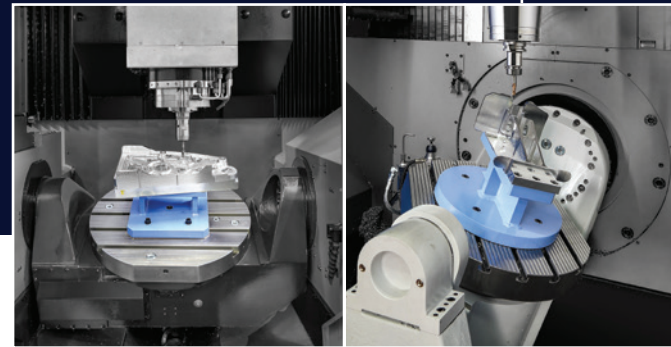

Table on Table Vertical

DNM 200/5AX, DNM 350/5AX

Built off the popular DNM vertical machining center platform, these models were designed with the trunnion table in mind, giving you ample axes stroke to machine your part. Available in either 5-face or Full 5 configurations.

- A/C axes in the table
- 12000 r/min spindle
- 30 tool magazine
- FANUC/HEIDENHAIN controller
- Perfect for small parts found in the aerospace industry



Traveling Column Vertical with Fully Integrated Table

FM 200/5AX, FM 350/5AX, VC630/5AX, DVF 5000, DVF 6500, DVF 8000

A wide array of rigid traveling column verticals with fully integrated tables designed for small precision medical parts to large aerospace jet engine components. A perfect place to start if you're looking for simultaneous full 5-axis models.

- Fully integrated A/C or B/C table design
- 12000 to 42000 r/min spindle variations
- 24 - 121 tool magazine variations
- CUFOS, FANUC, HEIDENHAIN or SIEMENS controller
- ø200 (7.9 inch) through 800mm (31.5 inch) size rotary table offerings

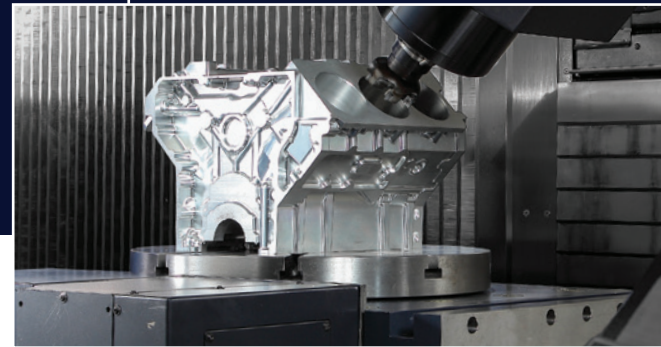
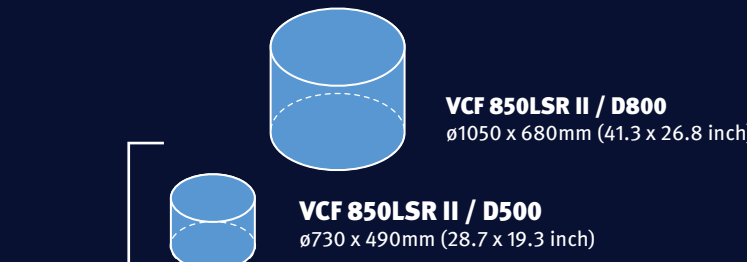

Traveling Column Vertical with Tilting Spindle Head

VCF 850LSR II/D500, VCF 850LSR II/D800

A versatile large vertical machining center with excellent table-to-base weight distribution allows you to run heavier workpieces that a conventional machine can't handle. Minimize tool interference with the full range tilting spindle head.

- Tilting B-axis spindle head with C-axis rotary table
- 12000 or 18000 r/min spindle option
- 30 - 60 tool magazine option
- FANUC controller
- ø500 (19.7 inch) or 800mm (31.5 inch) size rotary table option

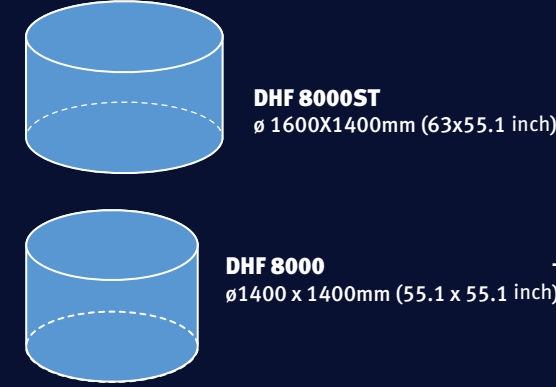

Nodding Spindle Horizontal

DHF 8000/8000ST

An 800mm pallet size horizontal with a heavy duty geared head spindle paired with dual ballscrews in the Y and Z axes and scales for accuracy. The nodding A-axis spindle allows you to machine added features without creating extra setups.

- 800mm (31.5 inch) pallet horizontal machining center with full B-axis table
- 6000 r/min spindle option with nodding A-axis
- 60 - 376 tool magazine option
- FANUC/SIEMENS controller

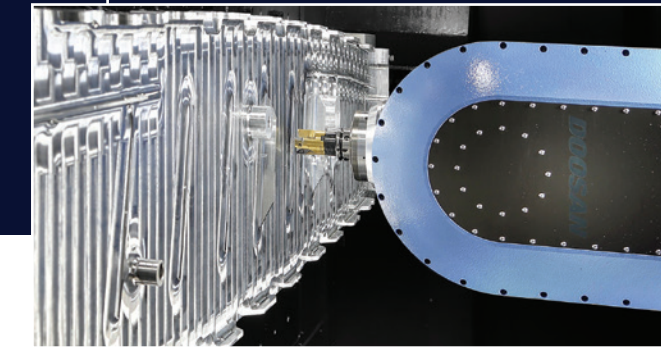
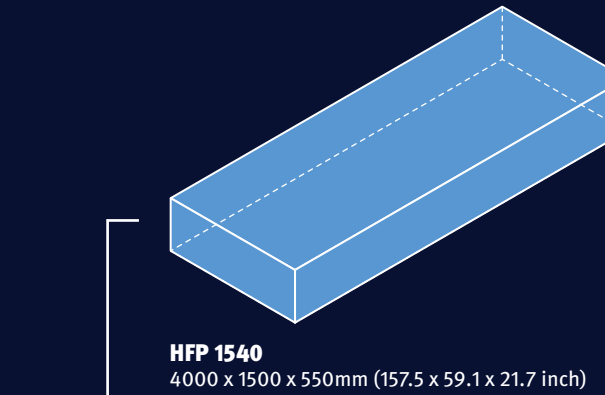

Universal Spindle Head Horizontal

HFP 1540

A super high speed horizontal profiler capable of finishing large aluminum structural components often found in the aerospace industry. The automatic pallet changer is a standard feature giving you the added productivity.

- A/C axes in the spindle
- 30000 r/min spindle
- 60 tool magazine
- SIEMENS controller

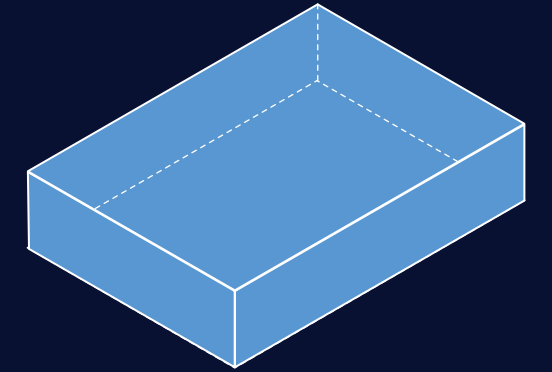

Bridge Mill Machine with Universal Head Attachment

BM 2035U, BM 2740U

The 5-axis universal spindle head attachment allows this multi-purpose bridge mill series to become a simultaneous 5-axis powerhouse. The BM series offers two different sizes.

- Simultaneous 5-axis universal spindle head attachment (OP)
- 8000 - 18000 r/min spindle
- 40 - 60 tool magazine option
- HEIDENHAIN controller
- Perfect for die mold applications found in the automotive industry

DNM series

3+2, 4+1



Your 5-Axis Entry Machine

Introduce 5-axis technology to your customer with the DNM 5AX series. The first time you machine complex parts in a single setup, you never go back. That's because the time, money and operator error you save instantly changes the way your shop does business. Sporting high rigidity roller guides for all axes, the DNM 5AX will take you where you want to go.

VCF series

Multi 5-axis

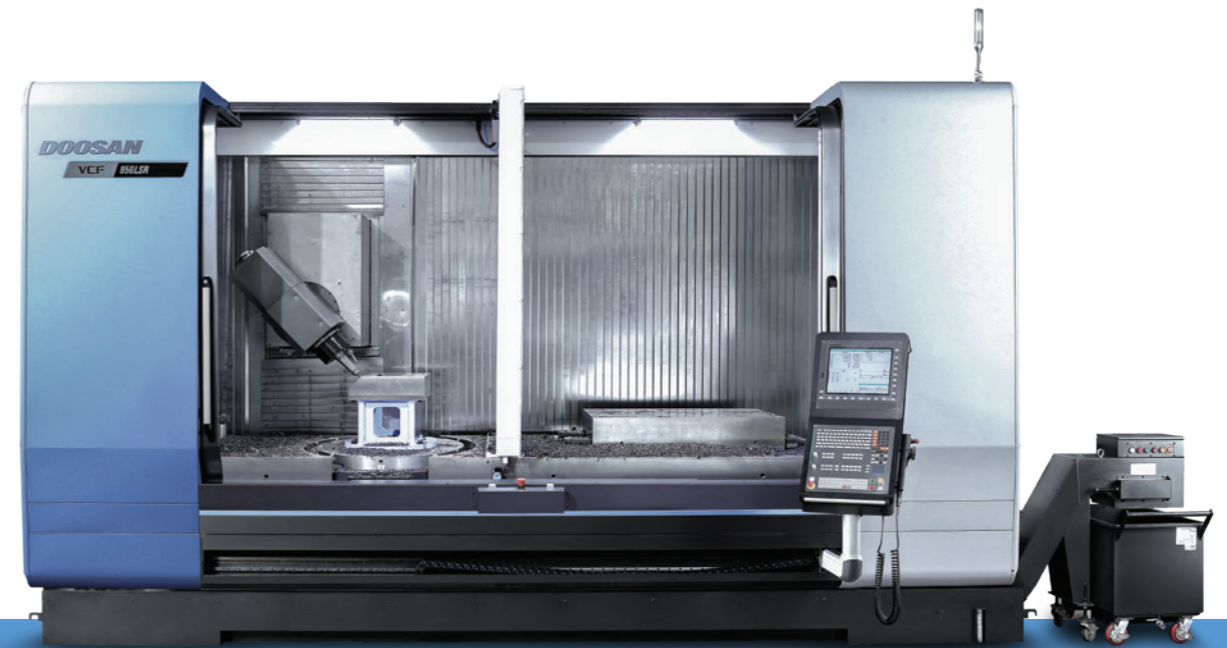

One Machine, Multi-Purpose Productivity

The VCF series, our traveling column vertical machining center with a rotating B-axis spindle head and C-axis table, is a fantastically flexible way to get more 5-axis production out of a single machine.

Thoughtful Design

The DNM 5AX series has a built-in 5-axis trunnion table. Select your rotary table diameter and enjoy maximized productivity. By designing the machine around the trunnion table, your machining area is maximized and any dead space is minimized.

DNM Architecture

There are currently over 30000 DNM series installed all over the world. The reliable vertical machining centers use their versatility and technical prowess to change machine shops for the better, and that's the foundation you get in the DNM 5AX series.

Fixed Table Design

The roller guideways, BIG-PLUS® spindle and fixed table give the VCF series the supreme rigidity you need for your applications. And through it all, it stays precise and temperature-controlled with the ball screw nut and mount cooling.

Large Scale. Long Table.

If you need a lot of X-axis travel, 3000 millimeters should be enough. That's the table length on the VCF series, and that length accommodates a variety of workpieces, giving you the room to get creative with your machining cycle setup.

	DNM 200/5AX	DNM 350/5AX	VCF 850LSR II / D500	VCF 850LSR II / D800
Spindle Orientation	Vertical	Vertical	Vertical w/B-axis spindle head	Vertical w/B-axis spindle head
Rotary Table Diameter	Ø200mm (7.9 inch)	Ø350mm (13.8 inch)	Ø500mm (19.7 inch)	Ø800mm (31.5 inch)
Tool Shank	BT/CAT/DIN 40	BT/CAT/DIN 40	BT/CAT/DIN 40	BT/CAT/DIN 40
Spindle Speed	12000 r/min	12000 r/min	12000 r/min	12000 r/min
Spindle Power	18.5/11 kW (24.8/14.8 hp)	18.5/11 kW (24.8/14.8 hp)	22/18.5 kW (29.5/24.8 hp)	22/18.5 kW (29.5/24.8 hp)
Number of Tools (min-max)	30-40	30-60	30-60	30-60
Max. Table Capacity	40 kg (88.2 lb) (Horizontal), 60 kg (132.3 lb) (Vertical)	250 kg (551.2 lb)	3500 kg (7716.2 lb)	3500 kg (7716.2 lb)

FM series

Full 5-axis vertical machining center



VC/5AX series

Full 5-axis vertical machining center



Unbelievable High Speed and Precision

The FM Series boasts an ultra-compact footprint and great reliability thanks to its 42000 r/min high speed spindle and linear axes driven by linear motors. On top of that speed, the machine also brings high stability during machining.

Get the Complex Job Done Right

An 81-tool magazine is standard in the VC 630/5AX. But you can go higher. The more complex the part, the more tools are required. The VC gives you 81 tools out of the box and offers options of up to 121 tools.

Stable Bed and Structure Design

The FM series offers stable cutting based on anti-vibration materials and symmetrical gantry structure. A 42000 r/min spindle, X/Y/Z linear motors and direct drive motors in the trunnion table bring productivity and accuracy.

HEIDENHAIN Controlled Reliability

The adoption of HEIDENHAIN controllers, optimized for high speed processing, increases the FM's reliability, visibility and display applicability. This is one smart machine.

Dependable Cuts

The VC 630/5AX has a built-in 12000 r/min spindle that is supported by high precision ceramic bearings and monitored by a thermal sensor for micron level accuracy. Combined with a standard BIG-PLUS taper, you get more rigidity, less vibration and cuts you can rely on.

Optional Pallet Changer

If you want to increase productivity and unattended running time on your VC 630/5AX, then you can include an auto pallet changer. This will improve your efficiency and bottom-line profitability.

	FM 200/5AX	FM 350/5AX
Spindle Orientation	Vertical	
Rotary Table Diameter	Ø200mm (7.9 inch)	Ø350mm (13.8 inch)
Tool Shank	HSK E40	
Spindle Speed	42000 r/min	
Spindle Power	12.6 kW (16.9 hp)	10 kW (13.4 hp)
Number of Tools	24	40
Max. Table Capacity	15 kg (33.1 lb)	100 kg (220.5 lb)

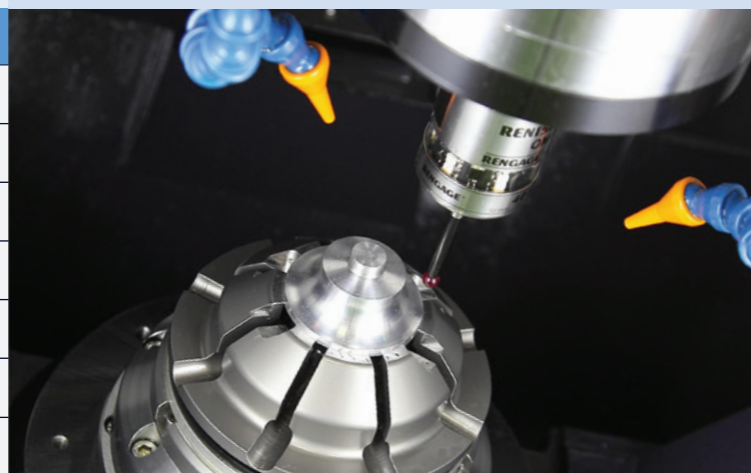

Spindle Orientation	Vertical
Rotary Table Diameter	Ø630mm (24.8 inch)
Tool Shank	BT/CAT/DIN 40
Spindle Speed	12000 r/min
Spindle Power	22/18.5 kW (29.5/24.8 hp)
Number of Tools (min-max)	40-121
Max. Table Capacity	500 kg (1102.31 lb)

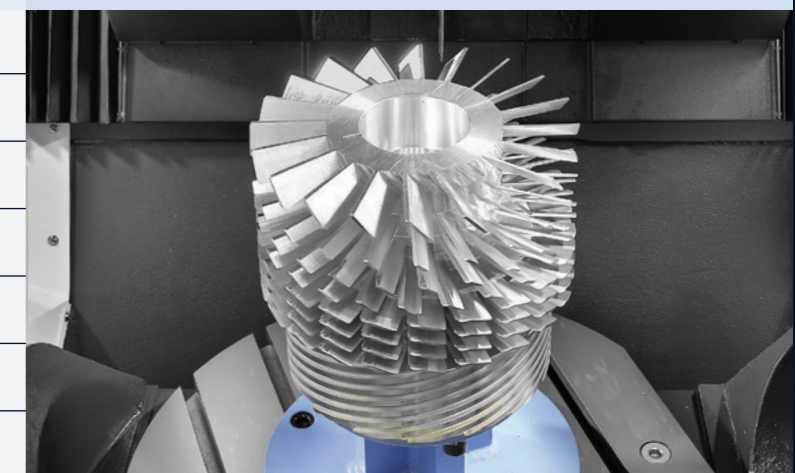

DVF series

Full 5-axis vertical machining center



Complex Parts. Single Setup.

Everyone starts somewhere, and many machine shops start with a process that involves multiple setups and extra downtime. But eventually, there comes a day when a true 5-axis is the right fit. When that day comes, the DVF series and its integrated 5-axis table is an unbeatable option.

Automation-Ready Workhorse

Speed meets strength in the DVF series. An 18000 r/min spindle gives total access to the part while maintaining rigidity, and the maximum of 120 tools and an automatic work changer are made for lights out machining.

Compact and Spacious

Yes, it's both at the same time. The compact footprint of the DVF series fits comfortably in the smallest of machine shops, and the spacious work envelope allows for machining of parts up to 400 kilograms.

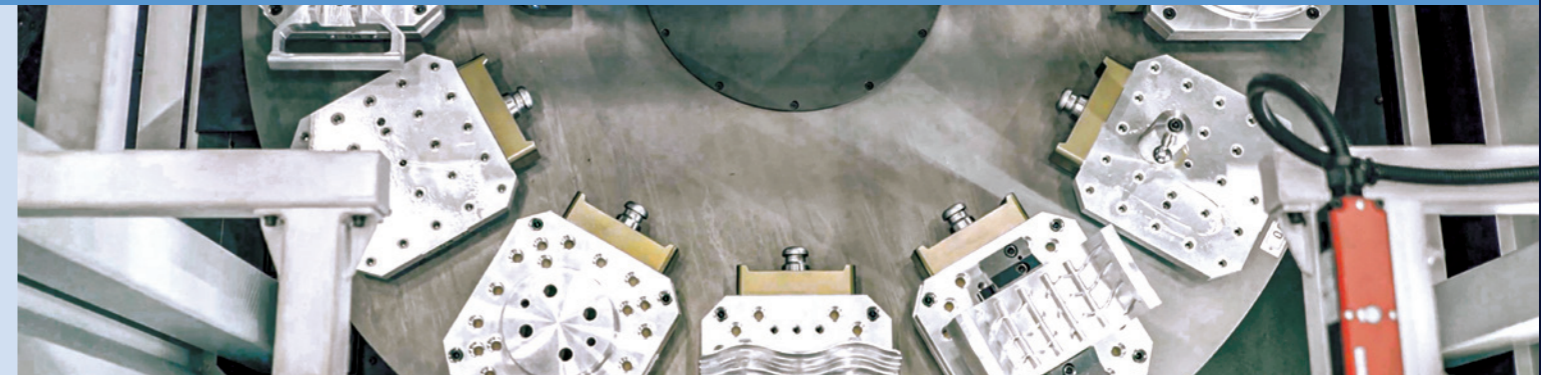

	DVF 5000	DVF 6500	DVF 8000
Spindle Orientation	Vertical	Vertical	Vertical
Rotary Table Diameter	Ø500mm (19.7 inch)	Ø650mm (25.6 inch)	Ø800mm (31.5 inch)
Tool Shank	BT/CAT/DIN 40	BT/CAT/DIN 40	BT/CAT/DIN 40
Spindle Speed	12000 r/min	12000 r/min	12000 r/min
Spindle Power	22/18.5 kW (29.5/24.8 hp)	22/18.5 kW (29.5/24.8 hp)	22/18.5 kW (29.5/24.8 hp)
Number of Tools (min-max)	30 - 120	40 - 120	40 - 120
Max. Table Capacity	400 kg (881.8 lb)	600 kg (1322.8 lb)	1400 kg (3086.5 lb)

DHF series

Horizontal machining center

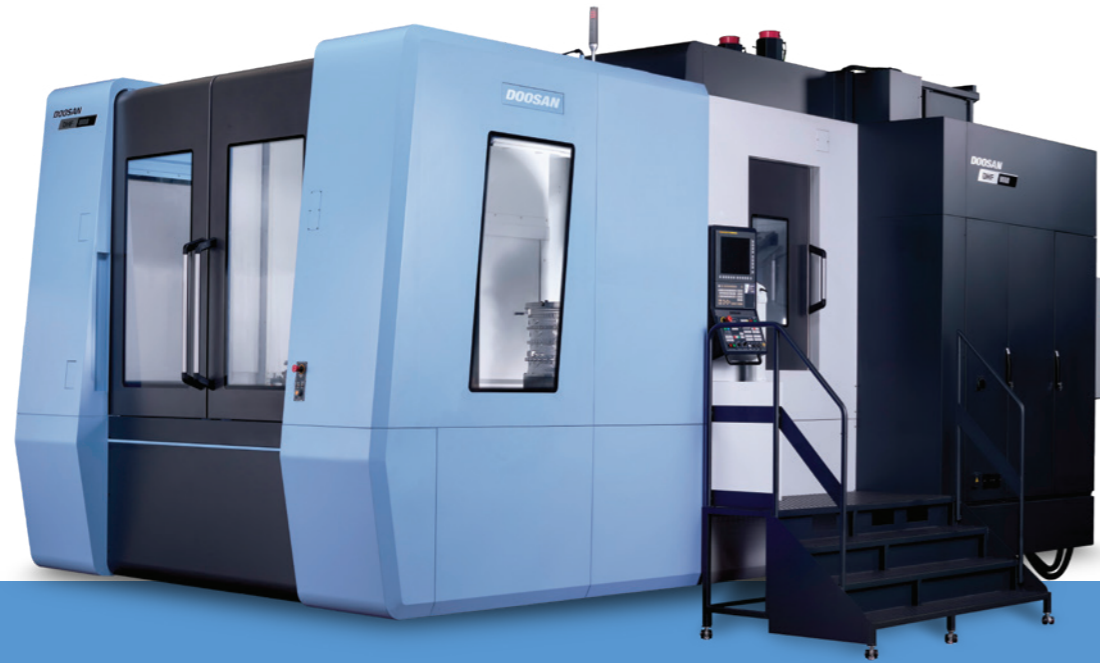

Built to Handle Large Complex Parts

This is for all aerospace, oil/gas and automotive machine shops. Thanks to its robust design, 800mm twin pallets, built-in precision and minimum footprint, the DHF 8000 gobbles up large part applications in aerospace, oil field, automotive and other industries. Complex parts are handed with the utmost efficiency.

HFP series

Aerospace profiler



Unbelievable Speed

Remarkable chip-making ability. The lightning-fast 30000 r/min universal head spindle on the HFP 1540 is powered by a 100 horsepower motor. It's got the speed and power you need for high-volume aluminum removal, and its 5-axis universal head is capable of angles you won't get with typical horizontals.

Unbeatable Range of Features

Take some time to watch the DHF 8000 in action. Its dual ballscrews and stable machine structure ensures total rigidity, and its linear scales and temperature compensation give you higher precision than before. The large number of tools available handles even the most complex job.

Single-Setup Productivity

The nodding head A-axis spindle and B-axis rotary table allow the DHF 8000 to handle a full range of machining processes. This configuration makes quick work of the 5-axis simultaneous machining of complex shapes.

Size and Strength

The HFP's integrated uni-body frame ups its stability. Large workpieces are easily accommodated with the HFP's impressive X/Y/Z travels, and the machine's rapid traverse of up to 60 m/min gives excellent cycle time—even with that big table and long travels.

Next-Level Aerospace

The shop best suited for what the HFP can do is the one that's ready to diversify its aerospace work and jump into machining some of the largest parts in the industry. Everything about it was designed for massive metal removal rates.

DHF 8000/8000ST

Spindle Orientation	Horizontal with A-axis
Rotary Table Diameter	Ø800mm (31.5 inch)
Tool Shank	BT/CAT/DIN 50
Spindle Speed	6000 r/min
Spindle Power	35/22 kW (46.9/29.5 hp)
Number of Tools (min-max)	60-376
Max. Table Capacity	2000 kg (4409.2 lb)



HFP 1540

Spindle Orientation	Horizontal with universal spindle head
Rotary Table Diameter	N/A
Tool Shank	HSK A63
Spindle Speed	30000 r/min
Spindle Power	75/60 kW (100.6/80.5 hp)
Number of Tools	60
Max. Table Capacity	3000 kg (6613.9 lb)

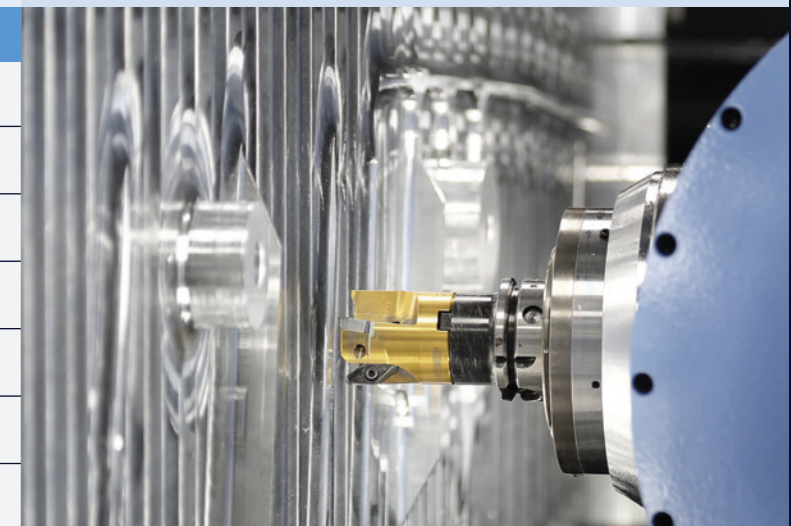

BM series

Bridge mill with universal spindle head



Strong and Stable Bridge Mill

If your machine shop works with oversized die mold applications, you would be wise to take a serious look at the BM series. It will be a welcome addition to your floor. A HEIDENHAIN control comes standard in the BM series. The state-of-the-art processing speed that's packed inside translates to exemplary 5-axis speed and accuracy.

Versatile Spindle, Rigid Machine

The two axis universal spindle head has ample rotating angles to let you access hard-to-machine areas, and multiple rails of linear roller guideways add to the BM's rigidity.

Higher Levels of Precision

Linear scales are a standard feature on all XYZ axes, which means the BM brings accuracy you can rely on. Thanks to its ball screw nut cooling and thermal displacement compensation, the machine stays precise.

BM 2035U

Bridge Mill w/universal spindle head

70~670mm (2.8~26.4 inch)

HSK A63

3000 r/min

75/60 kW (100.6/80.5 hp)

40-60

10000 kg (22046.2 lb)

BM 2740U

Bridge Mill w/universal spindle head

10~610mm (0.4~24.0 inch)

HSK A100

15000 r/min

45 kW (60.3 hp)

60

15000 kg (33069.3 lb)

Cover All Details

Doosan has one of the most comprehensive 5-axis lineups in the world. Bottom line—if you make complex parts, you'll find a Doosan 5-axis that's a perfect fit.

		X/Y/Z Axis Travel	Rotary Table Diameter	Maximum Workpiece Size	Spindle Speed
FM series	FM 200/5AX	200 x 340 x 300mm 7.9 x 13.4 x 11.8 inch	200mm 7.9 inch	ø300 x 320mm 11.8 x 12.6 inch	42000 r/min
	FM 350/5AX	400 x 600 x 350mm 15.7 x 23.6 x 13.8 inch	350mm 13.8 inch	ø350 X 300mm 13.8 X 11.8 inch	42000 r/min
DNM series	DNM 200/5AX	400 x 435 x 500mm 15.7 x 17.1 x 19.7 inch	200mm 7.9 inch	ø300 x 200mm 11.8 x 7.9 inch	12000 r/min
	DNM 350/5AX	600 x 655 x 500mm 23.6 x 25.8 x 19.7 inch	350mm 13.8 inch	ø400 x 335mm 15.7 x 13.2 inch	12000 (20000) r/min
DVF series	DVF 5000	625 x 450 x 400mm 24.6 x 17.7 x 15.7 inch	500mm 19.7 inch	ø550 x 450mm 21.7 x 17.7 inch	18000 (12000) r/min
	DVF 6500	750 x 785 x 600mm 29.5 x 30.9 x 23.6 inch	650mm 25.6 inch	ø840 x 500mm 33.1 x 19.7 inch	12000 (18000) r/min
	DVF 8000	1000 x 900 x 685mm 39.4 x 35.4 x 26.7 inch	800mm 31.5 inch	ø1000 x 590mm 39.4 x 23.2 inch	12000 (18000) r/min
VC/5AX series	VC 630/5AX	650 x 765 x 520mm 25.6 x 30.1 x 20.5 inch	630mm 24.8 inch	ø730 x 500mm 28.7 x 19.7 inch	12000 (20000/ 30000) r/min
VCF series	VCF 850LSR II/D500	3000 x 850 x 800mm 118.1 x 33.5 x 31.5 inch	500mm 19.7 inch	ø730 x 490mm ø28.7 x 19.3 inch	12000 (18000) r/min
	VCF 850LSR II/D800	3000 x 850 x 800mm 118.1 x 33.5 x 31.5 inch	800mm 31.5 inch	ø1050 x 68mm 41.3 x 26.8 inch	12000 (18000) r/min
DHF series	DHF 8000/8000ST	1450 x 1200 x 1500mm 57.1 x 47.2 x 59.1 inch	800mm 31.5 inch	ø1400 x 1400mm 55.1 x 55.1 inch	15000 (30000) r/min
HFP series	HFP 1540	4200 x 1600 x 550mm 165.4 x 63 x 21.7 inch	N/A	4000 x 1500mm 157.5 x 59.1 inch	30000 r/min
BM U series	BM 2035U	2500 x 2050 x 800mm 137.8 x 80.7 x 31.5 inch	N/A	3500 x 1850mm 137.8 x 72.8 inch	8000 r/min
	BM 2740U	4000 x 2500 x 700mm 157.5 x 98.4 x 27.6 inch	N/A	800 x 2500mm 157.5 x 98.4 inch	18000 r/min

5-AXIS. NO LIMITS.

The 5-axis lineup at Doosan was built by relentless R&D. If you're ready to experience the best 5-axis value in the world—backed by renowned applications, service and support—talk to your local distributor today.



doosanmachinetools.com

Head Office

22F T Tower, 30, Sowol-ro 2-gil
Jung-gu, Seoul, Korea, 04637

Tel: +82-2-6972-0370/0350

Fax: +82-2-6972-0400

Doosan Machine Tools America

19A Chapin Road, Pine Brook
New Jersey 07058, United States

Tel: +1-973-618-2500

Fax: +1-973-618-2501

Doosan Machine Tools Europe

Emdener Strasse 24, D-41540
Dormagen, Germany

Tel: +49-2133-5067-100

Fax: +49-2133-5067-111

Doosan Machine Tools India

No.82, Jakkuar Village
Yelahanka Hobli, Bangalore-560064

Tel: + 91-80-2205-6900

E-mail: india@doosanmt.com

Doosan Machine Tools China

Room 101,201,301, Building 39 Xinzhuan
Highway No.258 Songjiang District
China Shanghai (201612)

Tel: +86 21-5445-1155

Fax: +86 21-6405-1472

Sales inquiry

sales@doosanmt.com

*For more details, please contact Doosan Machine Tools.

*Specifications and information contained within this catalogue may be changed without prior notice.

*Doosan Machine Tools Co., Ltd. is a subsidiary of MBK Partners. The trademark **DOOSAN** is used under a licensing agreement with Doosan Corporation, the registered trademark holder.



**Fire Safety
Precautions**

There is a high risk of fire when using non-water-soluble cutting fluids, processing flammable materials, neglecting the controlled and careful use of coolants and modifying the machine without the consent of the manufacturer. Always check the SAFETY GUIDELINES carefully before using the machine.

ver. EN 210608 SU